



Mona Relief Grande Aria

The Mona Relief Grande Aria irrigation unit has a vented irrigation inlet, it is easy to install and delivers water directly to the tree or shrub roots at a consistent level.

Features

- Flip top grid for faster filling
- Cost effective
- Large water filling capacity
- Grid inlet limits blockages
- Allows water and air to access the irrigation pipe

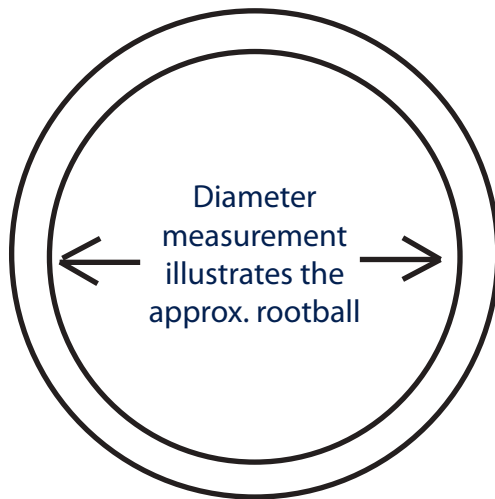

Model	Diameter of Irrigation Ring	Application Type
MRGA3	900mm	Large shrubs and trees up to approximately 20-25 girth
MRGA5	1530mm	Trees with larger rootballs. 25cm girth and upwards, check rootball size and match irrigation accordingly
MRGA8	2500mm	Trees with larger rootballs. 25cm girth and upwards, check rootball size and match irrigation accordingly
MRGA8D	2500mm (double inlet)	Aeration pipe, allows water and oxygen to reach the outer tree rooting area, improving soil health

Green-tech endeavour to ensure that the information given on this technical data sheet is accurate, but accept no liability for its use or its suitability for particular application.

Rabbit Hill Business Park, Great North Road, Arkendale, Knaresborough HG5 0FF

T: 01423 332100 E: sales@green-tech.co.uk W: www.green-tech.co.uk Facebook: @greentechuk Twitter: @greentechltd

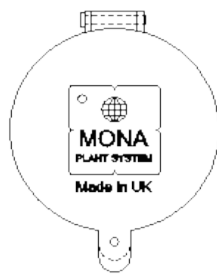

PLAN

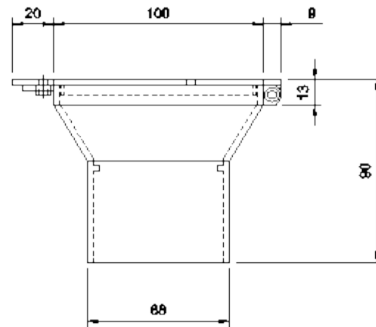

ELEVATION

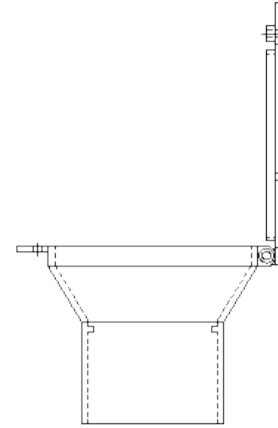

OPEN

Application

1. Place tree root ball in hole as with normal planting instructions.
2. Measure the circumference of the root ball and cut the Mona Relief pipe to the required size. Connect both ends of the pipe to the Mona Relief T junction. The Mona Relief is most efficient when positioned within the top third of the rootball.
3. Insert the Mona Relief feeding pipe with cap into the T junction.
4. Back fill the area covering the Mona Relief ring and feeding pipe evenly, ensuring it remains level at all times.
5. Leave space for the cap and feeding pipe to protrude from the ground, this prevents blockages of soil, stones and mulches.

Specification

It is recommended that when an urban tree is planted a tree irrigation system is put in place to ensure the tree receives the best start. By proactively installing a system that will irrigate at the root ball, the tree's roots instantly receive the much needed water to aid growth.

All Mona Relief inlets are available with varying irrigation pipe sizes, dependant on the root ball size.